

Chair Assembly Instructions

Carefully unpack all parts and identify them against the parts list before attempting to assemble. To avoid scratching the components, assemble the chair on a protected surface.

Note: The casters sold with this chair are intended for use on carpet and not recommended for use on tile or hard wood floors. Using these casters on tile or wood flooring may cause floor surface damage, so please consider purchasing a chairmat to protect your floor surfaces.

We are here to help if you have any questions, comments, or are in need of warranty replacement parts.







Call us toll free at: (02) 9621 1131



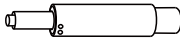

Attention:

1. Do not stand on the seat cushion.
2. For indoor use only.
3. Please do not expose to direct sunlight.
4. Please do not place this product near sources of excessive heat.
5. Please avoid use of sharp objects on or near this product.
6. Clean spills / marks immediately, as stains are harder to remove when they are left unattended.
7. For persistent stains and overall cleaning, contact a professional upholstery cleaning company.

OFFICE CHAIR

MC-1110E

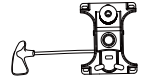
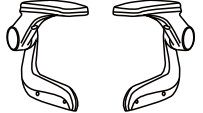
A		5
B		5
C		1
D		1
E		1
F		1
G	 M6x15mm	5

G1	 M6x25mm	10
G2	 M8x20mm	4
H		1
I		1
J		2
L	 5#	1

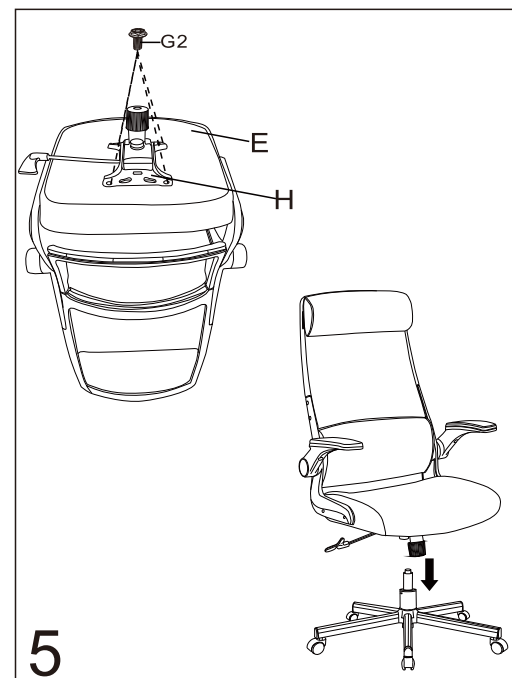
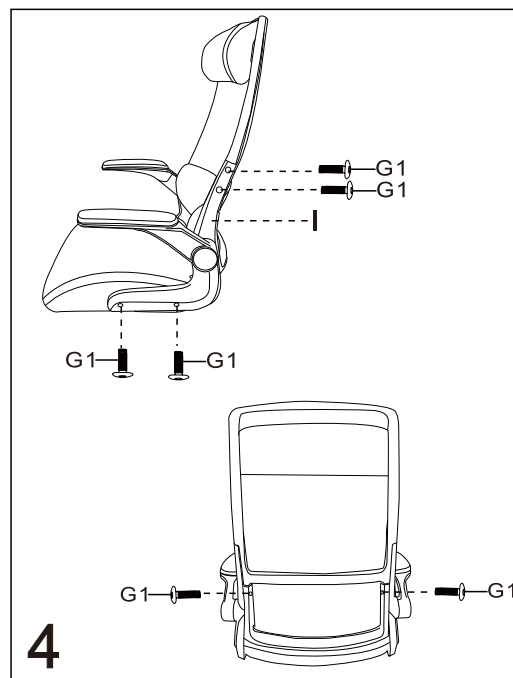
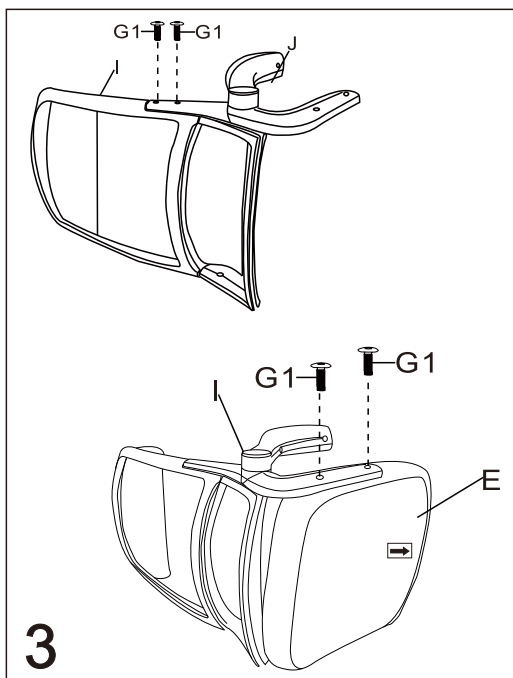
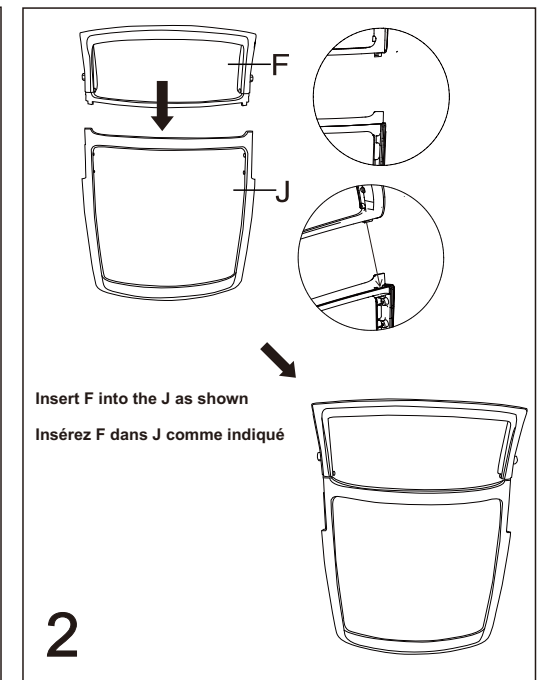
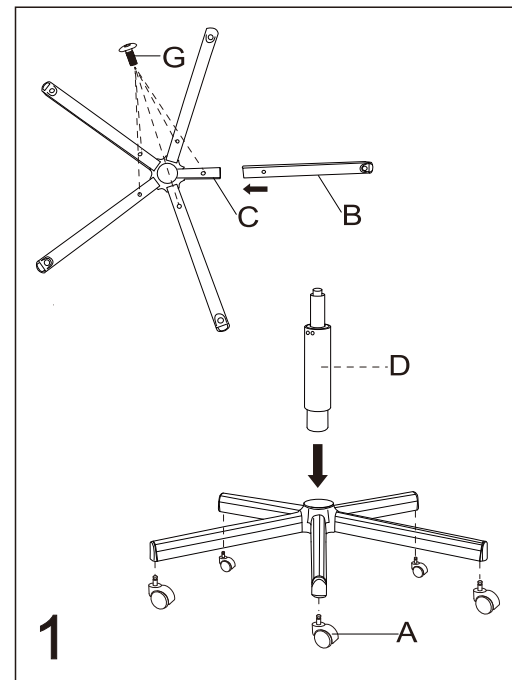

Limited Warranty

Huali Trading seating products are warranted against defects in material and workmanship while owned by the “Original Purchaser”. The term “Original Purchaser” is defined as that party or entity which purchases Huali Trading furniture from an authorized Huali Trading retailer as shown by the original sales receipt. This warranty does not apply to “as is” or previously owned seating products.

Huali Trading warrants its products to be free from defects in materials and workmanship (normal wear and tear, fading and stretching excepted), for 3 years from the date of purchase, except as provided below under the limited warranty.

The exceptions or exclusions to this warranty are as follows:

1. Upholstery material and foam cushion material is warranted against defects in material and workmanship for a period of 1 year, beginning on the date of purchase as shown on the original sales receipt.
2. Any warranty claim that is submitted after the limited warranty period, or without proper proof of purchase will not include the cost of parts, labour, or delivery.
3. This warranty shall not apply to Huali Trading products which have been subjected to misuse, neglect, alteration, modification or attachments, either caused by the original purchase, shipping, storage, accident, fire, flood or acts of God.

In the event of a defect in material or workmanship covered by this warranty, Huali Trading will repair or replace, at their discretion, without charge the warranted furniture within a reasonable amount of time. In the instance of a major failure to the product, Huali Trading will offer the option to either repair or replace at the customers' discretion. We reserve the right to require damaged parts to be returned to us upon request. Natural markings such as scars, brands, grain variations, wrinkles, colour variations, etc. will be considered normal characteristics and not construed as defects. We cannot warrant upholstery against scratching or scuffing, as all upholstery is subject to blemishes with use.

For claims or questions converting this warranty, please contact Huali Trading Customer Service department through email on services@hualitrading.com.au or the retailer the seating product was purchased from.

Huali Trading’s sole obligation and the users exclusive remedy under this warranty shall be limited to the repair, credit (only applies to distributors) or replacement at Huali Trading’s sole discretion and cost, of product or components under the **“COMPETITION AND CONSUMER ACT 2010”**.

Our goods come with guarantees that cannot be excluded under the Australian Consumer Law. You are entitled to a replacement or refund for a major failure and for compensation for any other reasonably foreseeable loss or damage. You are also entitled to have the goods repaired or replaced if the goods fail to be of acceptable quality and the failure does not amount to a major failure”.

All warranties are limited to the original purchaser for normal use which is defined as a standard work wee of forty hours by a person weighing less than 120kg.

OFFICE CHAIR

Warning:

1. Don' t use the chairs as the ladder to get the objects on the high position. It' s so dangerous to stand on the chairs.
2. Don' t let the children play on the chairs, rotating the chairs incessantly will cause injury to the children.
3. All plastic packing bags must be disposed properly. Don' t let the children have chance to touch the plastic packing bags, it may result in causing the children to asphyxiate.
4. Don' t lean so far back in your chairs that the wheels or legs lift up off the floor. Leaning can cause the chair to slip out from under you, cause structural damage, or can loosen important connections that can cause the chair to fall apart.
5. Never put all your weight at the very front edge of the chair. If you sit too far forward, the chair can tip over. Use a chair with a forward tilt mechanism if the task requires sitting in a forward position.
6. Don' t leave electrical appliances on upholstered chairs. Fire can result if they overheat. Be careful when smoking cigarettes or carrying lighted material around upholstered chairs.
7. Don' t overwork your chairs. Inspect and maintain your chairs at least 60 days.

Do' s:

1. Always follow the assembly direction completely. Make sure all the pieces are placed in the proper order so that the chair stays tight and together.
 2. Pay special attention to make sure the casters or wheels are fully inserted into the base of the unit.
 3. Every 6 month or so, make sure all the parts of the chair are tightened to ensure stability.
 4. Always keep the base of the chair completely on the floor.
 5. Always ensure that the tension control is properly adjusted, resulting in a smooth and controlled motion.
-
-