

Assembly Instruction/User Manual

LUNA Electric Standing Desk

Item Code: LU001 (White)

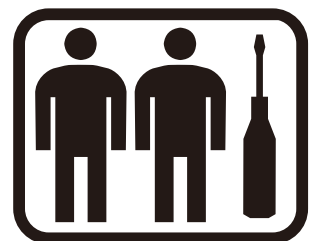

Two-person Assembly



PLEASE READ PRIOR TO INSTALLATION AND USE

Failure to comply with or observe all assembly, safety and operating instructions and warnings regarding the use of this product may result in serious bodily injury. When using an electrical furnishing, basic precautions should always be followed, read all instructions before using (this furnishing). **Huali Trading cannot be held liable for injury or damage caused by non-compliance with these instructions. Save these instructions and keep with the desk.**

This user manual contains important safety regulations. Any non-conforming use may result in personal injury or mechanical damage. Please read this user manual carefully before use as it provides key information about safety, use, assembly, and maintenance of the LUNA.

Close supervision by adults is necessary when the desk is used by, or near children, vulnerable or disabled persons. Use this desk only for its intended use as described in these instructions. Do not use attachments not recommended by the manufacturer. The LUNA is designed for indoor use and dry work areas only. Do not use outdoors. Do not operate in environments with high heat, high humidity, high salinity, or pollutant gases.



WARNING: To reduce the risk of electric shock, always unplug the desk from the electrical outlet before cleaning. To disconnect, remove the plug from the wall outlet. The LUNA is only to be used with the power supply provided.



WARNING: Only plug the desk into a properly grounded 120-240V outlet. Unplug the desk from the electrical outlet before moving the desk or before adding/removing parts or accessories.



WARNING: Keep heated surfaces away from plug. Never use a desk with a damaged cord or plug. Risk of electric shock. For replacement, please get in touch with the authorized retailer this desk was purchased from or email us: services@hualitrading.com.au



WARNING: In case of spilled liquids, immediately unplug desk. Then clean the spill with a dry cloth. The risk of desk failure or electric shock if desk electrical components become wet.



WARNING: Keep fingers and all body parts clear of the moving desk. Check surroundings on all sides before using the desk to ensure there are no immobile obstacles within the desk's range of motion. Ensure all cords are the appropriate length so they do not pull as the desk moves.



PLEASE READ PRIOR TO INSTALLATION AND USE

The LUNA is to be assembled by at least two people. This product contains small items that could be a choking hazard if swallowed. Keep these items away from children and pets. Do not overtighten the screws during installation.



This desk is not intended for use by children without adult supervision. Ensure children do not play with the desk and its height adjustment mechanism.



Do not exceed the maximum load capacity of the LUNA (265lb/120kg, inclusive of the top).



Be mindful of your fingers and hands when closing the drawer.



Do not stand on the desk and do not use the desk as a climbing aid.



Do not sit on the desk.



Do not drag the desk across the floor. Do not wobble the desk forcefully on purpose.



Do not crawl or lie under the desk frame.

TOOLS



HARDWARE

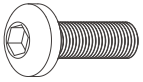

A(M8*18mm)x8+2(Spare)

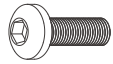

B(M6*15mm)x8+2(Spare)

PARTS

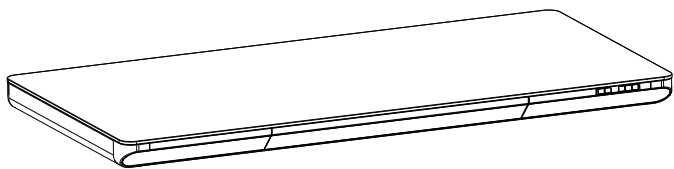

① X 1

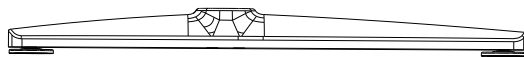

② X 2

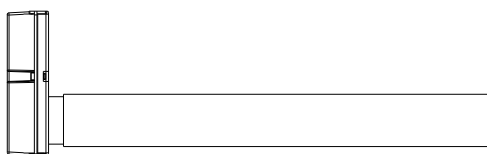

③ X 2

Assembly Instruction

1

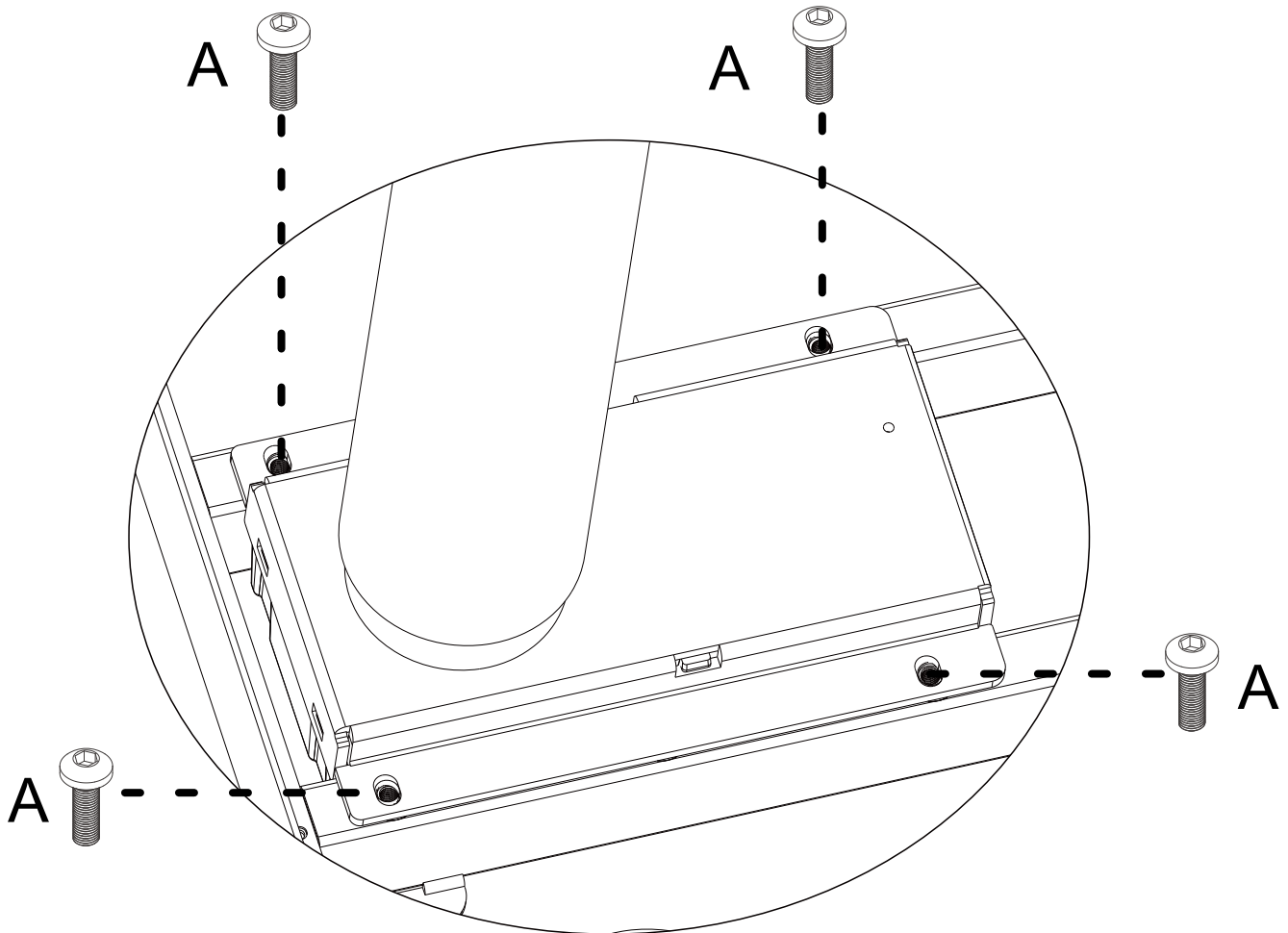
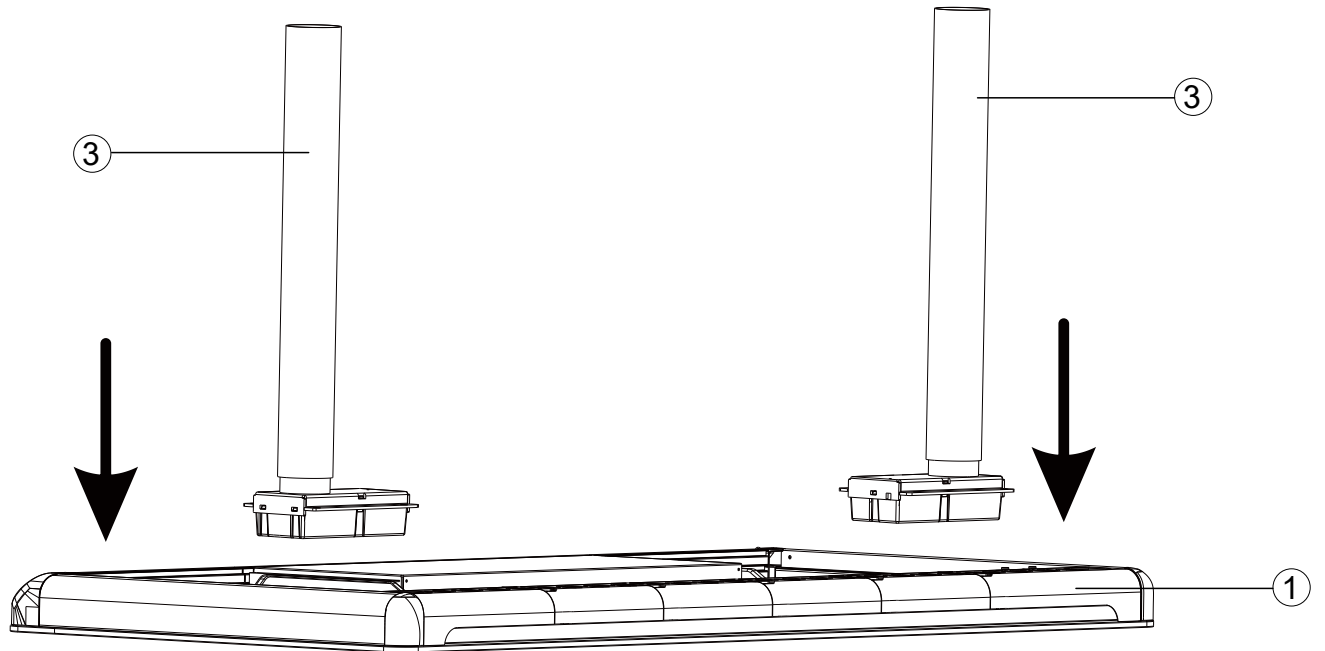

Assembly Instruction

2

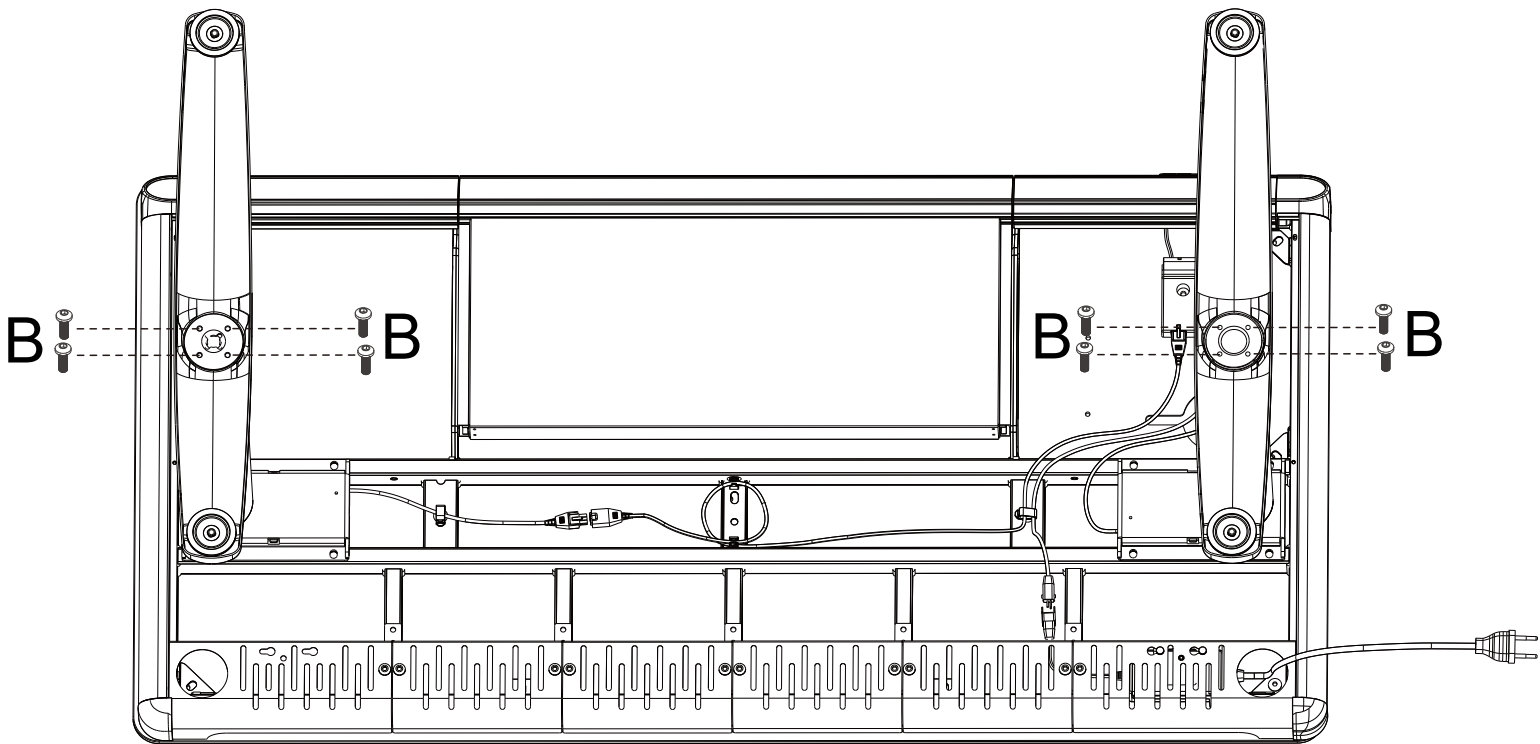
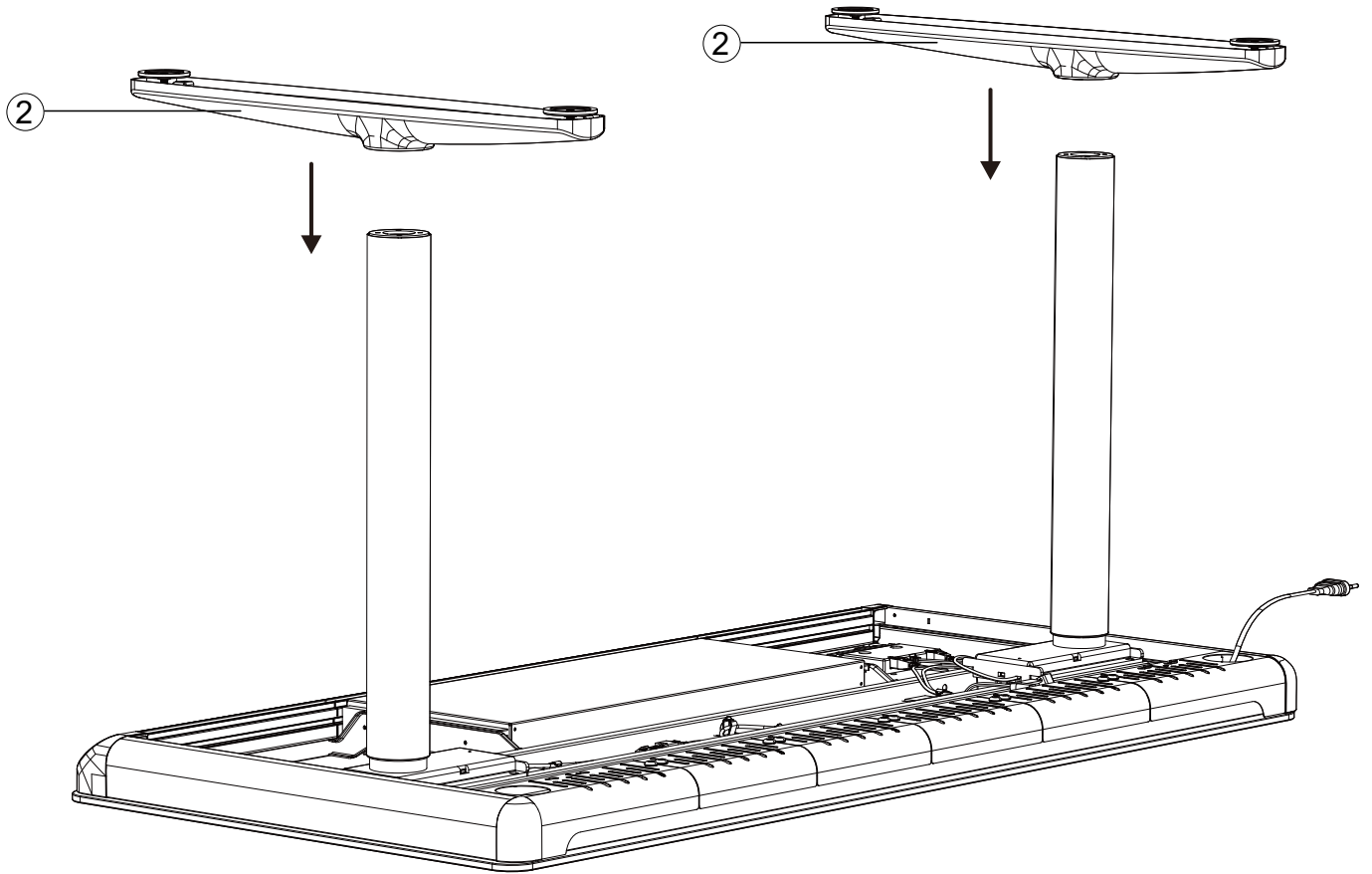

Assembly Instruction

3

! Do not connect the power before the cable connected with the adapter

Ensure the table is horizontal by adjusting the foot pad

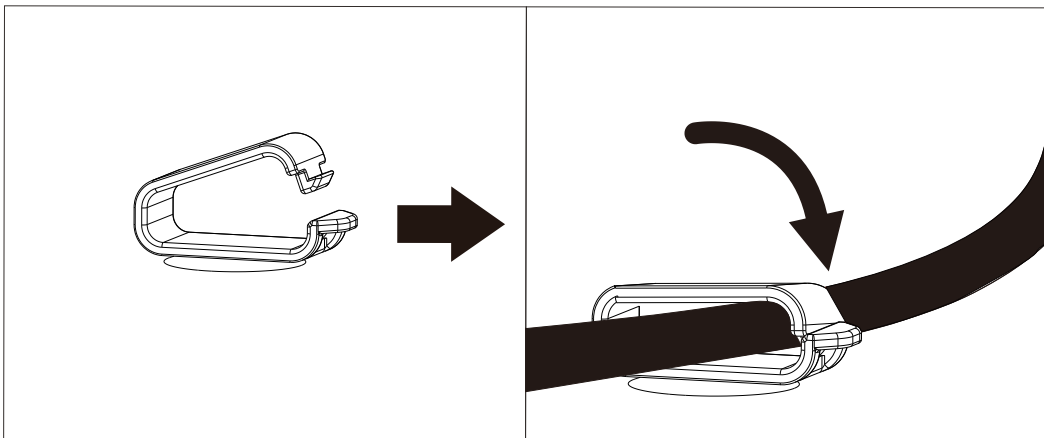
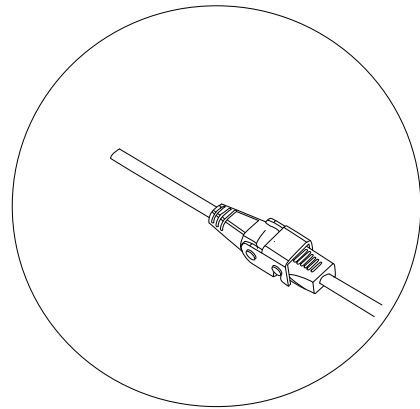
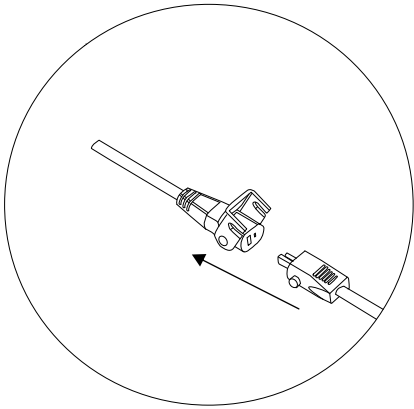
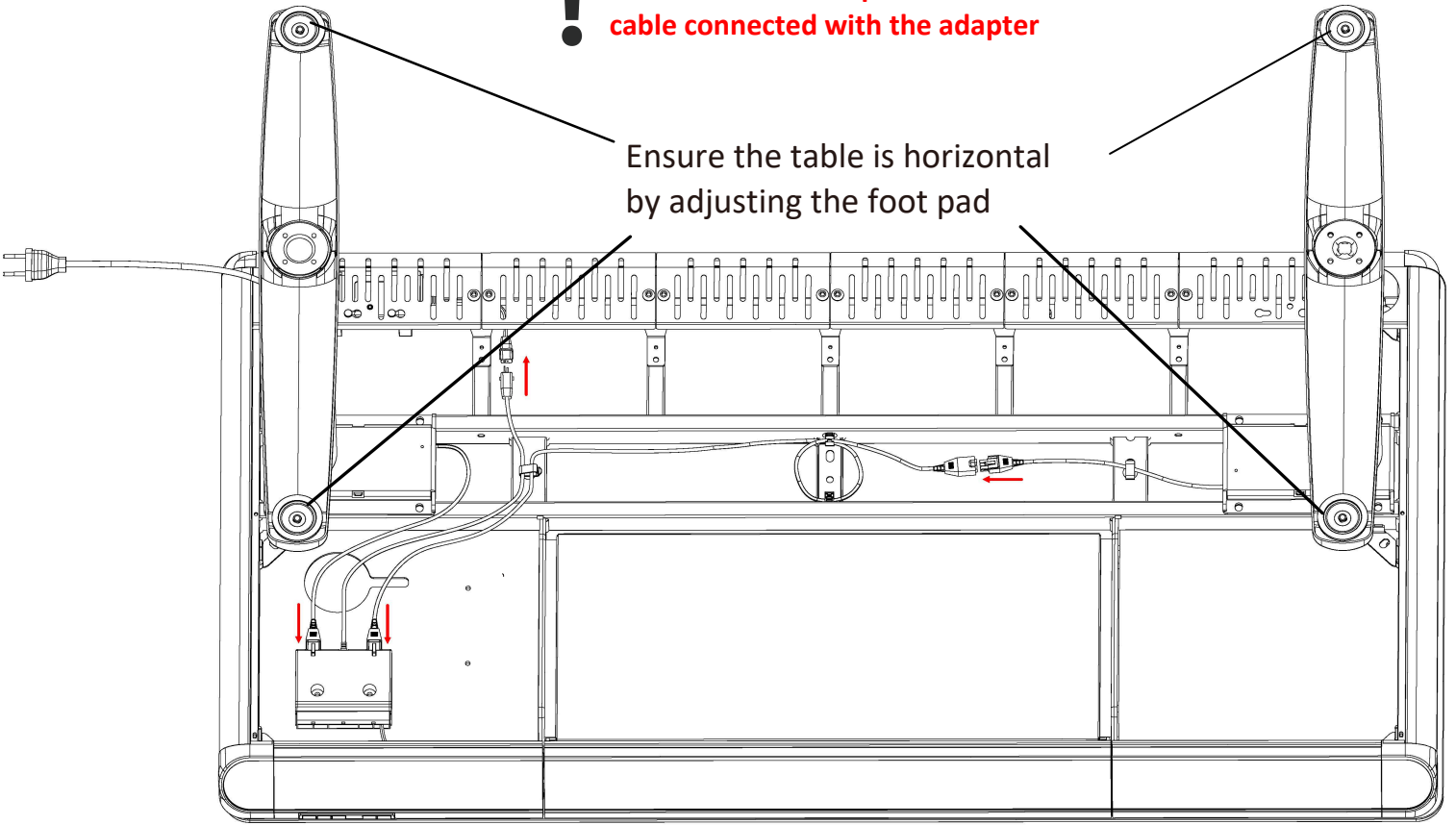

Assembly Instruction

4

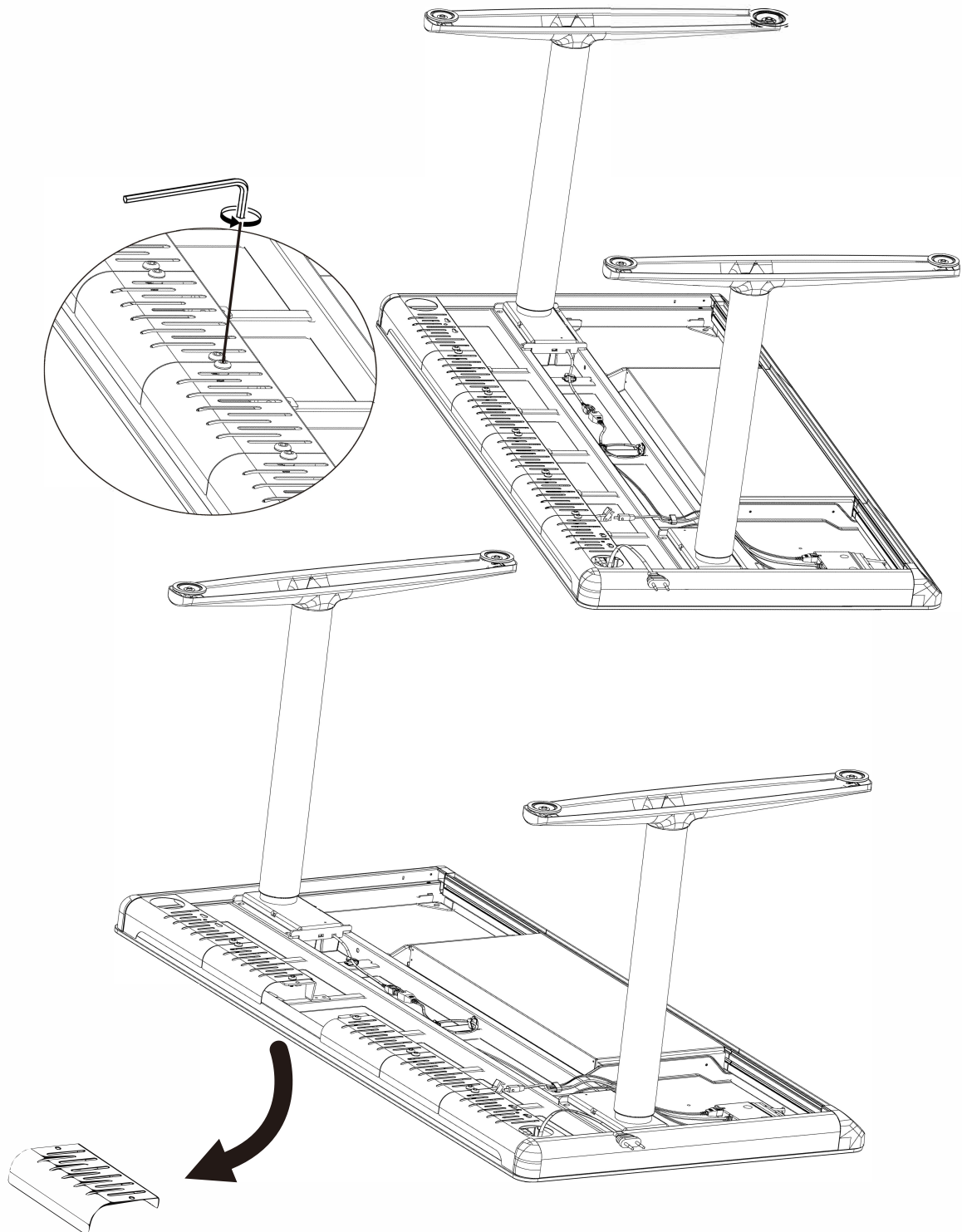

The cable management can be opened in this way to put sockets and electric wires

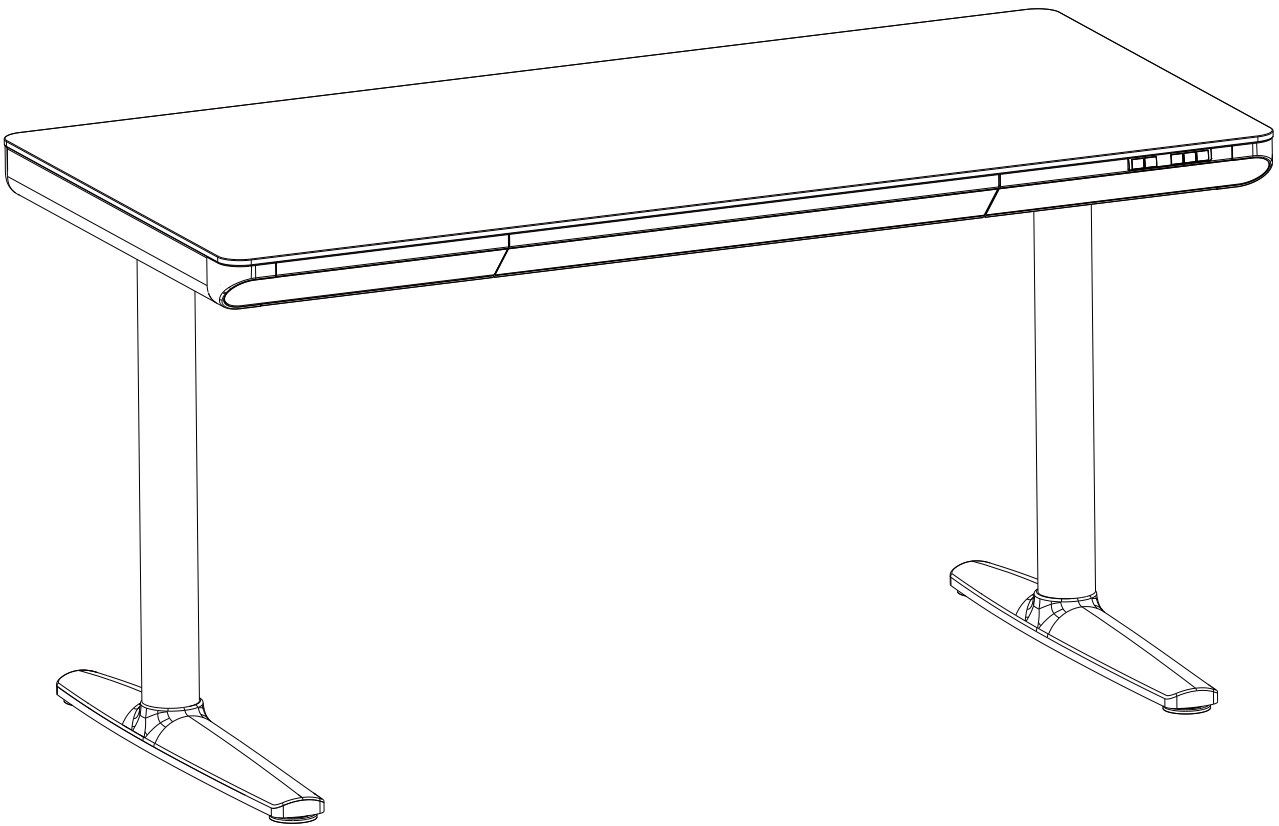

**Maximum weight
capacity 120kg**

**Maximum drawer
weight capacity 11kg**

Product Features Overview

An integrated cable management solution allows you to tidy your desktop or install a monitor arm



Includes a felt inlay stationary drawer for storage

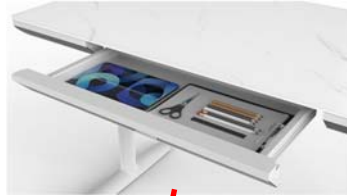

Commercial grade Compact Laminate desktop provides high resistance to impact, moisture, scratch and fire

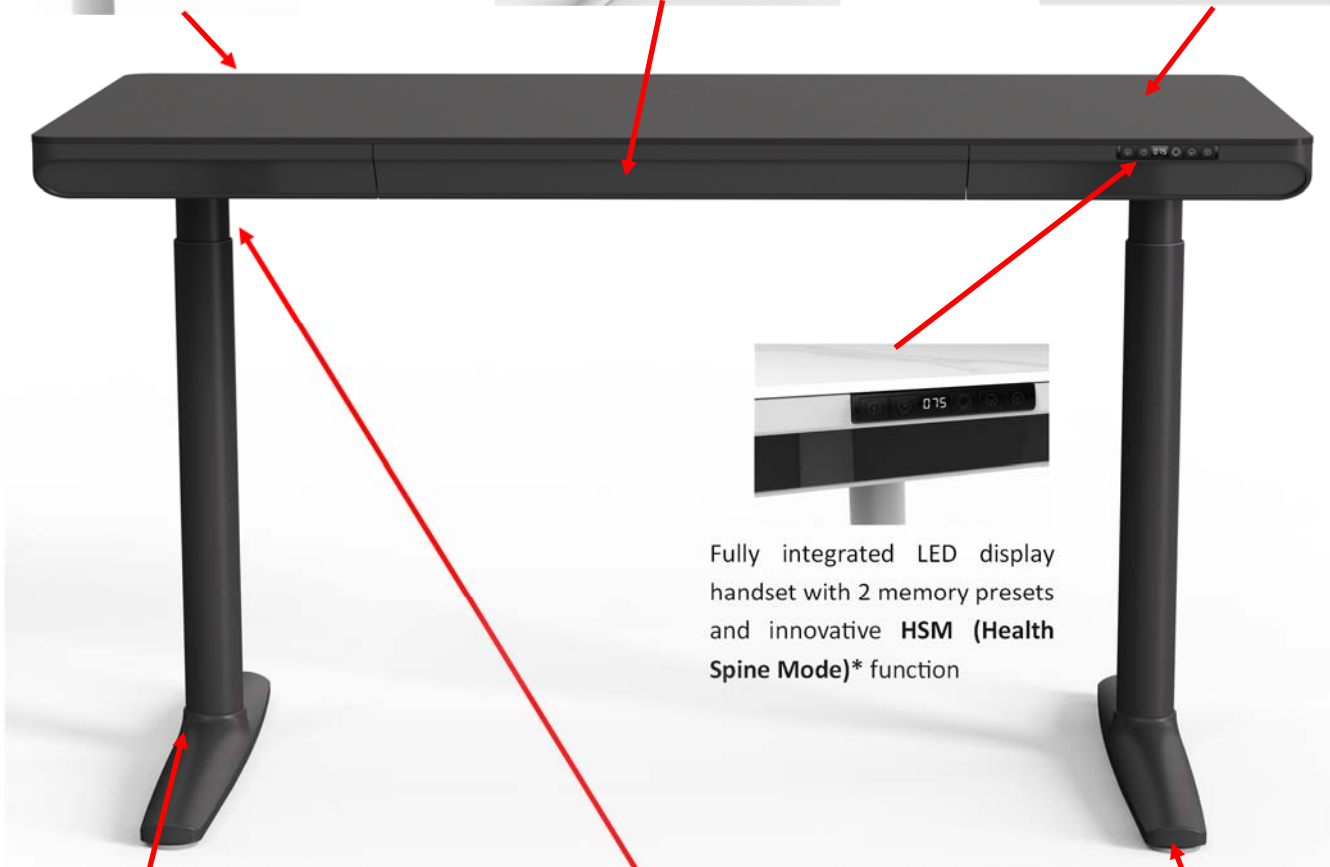

Fully integrated LED display handset with 2 memory presets and innovative **HSM (Health Spine Mode)*** function



2 stages designer round columns provides world class stability and rigidity



Dual motor lifting system (120kg) with anti-collision function



Includes height adjustable feet for uneven floor

** Press "HSM" button, the desk will make insensible movement upside from your sitting position by 12cm over 5mins, and later, it will come back to original position in another 5mins automatically. This technology is helpful for your neck and spine health by stretching them unintentionally.*

Controller User Guide

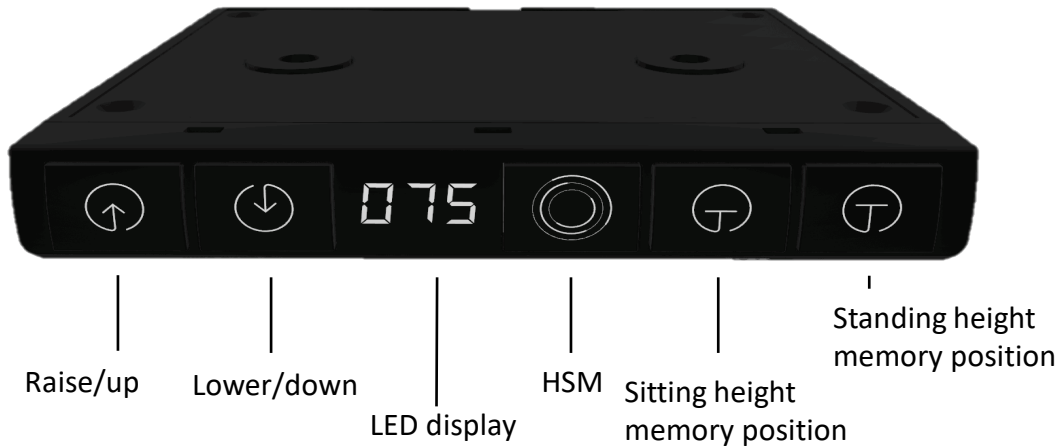

Notice

While raising or lowering the table, please make sure objects are secure on the table, and nothing prevents the table from raising or lowering through its desired range of adjustment.

Suggestion

Please set the preferred table height while sitting by pushing the "sitting position memory key", and the preferred table height while standing by pushing "the standing height memory key".

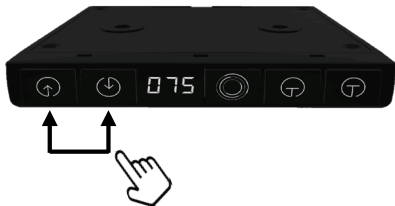

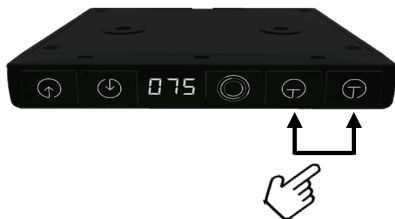



Table Height Adjustment

Press up  or down  to raise or lower the table to the preferred table height.



press 3 + seconds

Memory Presets

At the preferred lower table height for seated work, press the left  for 3+ seconds.

At the preferred higher table height for standing work, press the right  for 3+ seconds.

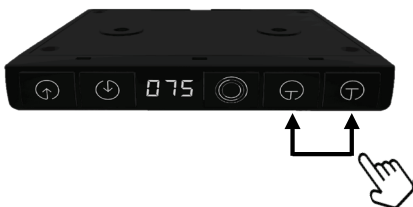

Use of Memory Keys

Briefly press the key left  and release, the table will move to the preferred seated work height.

Briefly press the key right  and release, the table will move to the preferred standing work height.

 Table adjustment stops by pressing any key on the control pad

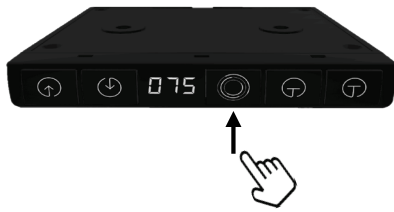

HSM mode-Health Spine Mode

When the light is flashing, the table will slowly move up 12 cm in 3 minutes, will stop for 2 minutes, and then will slowly move down by 12 cm in 3 minutes. After 2 minutes the movements will repeat.

“The best posture is the next posture”. Without breaking a sweat, without even noticing your involuntary body movement, you are, in fact, exercising your body.

Power ON/OFF

1. Press the  key to turn the operating system ON; the backlight light will be on;
 2. The system automatically shuts off after 1 hours.
- * If operating other keys, the backlight is off.

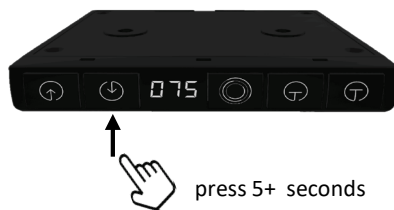







Reset control pad

In the lowest position or when prompted by the "protection and alarm" message, press the down arrow  for 5+ seconds, the table moves all the way down and will raise to a preset height at which time the reset is completed.

Notice: Objects under the table should be removed before the reset operation to prevent damage to table or other items.

Protection Features and Error Code Troubleshooting

-  Anti-interference: message/alarm “E02” appears when the desktop vibrates, is interfered with, or tilts during an adjustment. Stop adjustment immediately and reverse movement; after a certain adjustment the alarm will disappear.
-  Overheating protection: message/alarm “Hot” appears when continuous adjustment time exceeds 2 minutes, the overheating protection will be triggered. Stop adjustment immediately; wait for 18 minutes after which the alarm will disappear.
-  Motor malfunction protection: message/alarm “E10” appears. Power should be disconnected, re-check and ensure that the motor connected to the controller is secure, connect to power source.
-  Overload protection: message/alarm “E20” appears when the table is raised while overloaded. Remove weight, heavy objects from the table before adjustments. If overload occurs when lowering the table, please press the  for 5+ seconds to reset.
-  Out of Sync protection: message/alarm “E60” appears (multi-motor systems only!). Power should be disconnected, re-check and ensure that the motor connected to the controller is secure, connect to power source for reset.

COMPACT Laminate Care Guide

The compact laminate features a surface crafted from a melamine-based resin that possesses excellent stain resistance. Thanks to its remarkable durability and exceptional impermeability, maintaining the surface is a breeze. Simply wipe it with a dampened soft cloth with plain water or a mixture of household detergent, and it effortlessly removes all typical household spills.

General Cleaning

Using a mild household spray, wipe down the Compact laminate with a soft cloth. Dry using a soft cloth to avoid leaving any cleaning solutions on the surface.

You may also use Methylated Spirit on a soft cloth using a circular cleaning motion. Thoroughly clean over the broader area with water and detergent on a damp cloth afterwards to remove any residual Methylated Spirit.

Always refer to the recommendations provided by the cleaning product manufacturer before use.

To ensure that your warranty will not be void, **DO NOT** use any of the following on Compact laminate surfaces: Commercial Cleaning Products, Abrasive Cleaners, Scouring Pads or Abrasive Papers, Solvents, Thinners, Turpentine (Turps), Ammonia, Bleach, Acetone, Easy-Off BAM!, M.E.K. or any other cleaning agents containing organic solvents or the products mentioned above.

Please note: Huali Trading provides a limited Five (5) year warranty on all Compact laminate table tops which ensures against manufacturing defects. Failure to follow the above care instructions may damage your Compact product and void your entitlement to the warranty. **Huali Trading's** warranty does not cover wear and tear. For more information, refer to the **LUNA / LUNA LITE DESK** warranty document.

LUNA / LUNA LITE DESK Warranty

Huali Trading products are warranted against defects in material and workmanship while owned by the “Original Purchaser”. The term “Original Purchaser” is defined as that party or entity which purchases Huali Trading furniture from an authorized Huali Trading retailer as shown by the original sales receipt. This warranty does not apply to “as is” products.

Huali Trading warrants the LUNA range of products to be free from defects in materials and workmanship or defects that prevent normal operation and function for:

1. **“LUNA” DESK**
 - 10 Years on frame
 - 5 Years on motor and electronics
 - 5 Years on desk top
2. **“LUNA LITE” DESK**
 - 5 Years on frame
 - 3 Years on motor, electronics & desk top

What the limited warranty does not cover:

1. Normal wear and tear;
2. Improper assembly/disassembly;
3. Failure to follow provided safety warnings, setup and operating instructions and any other directions for proper operation;
4. Exceeding the maximum weight capacity rated for the desk(s)
5. Used outdoors or in environments with high heat, high humidity or high UV rays (direct sunlight);
6. Repairs, alterations or modifications performed by anyone not authorised by Huali Trading;
7. Defects caused in whole or in part by misuse, abuse, abnormal handling, negligence, impact, accident, fire or water damage and electrical overload;
8. Repair or replacement of other property damaged by a defective product or the cost of lost time/loss of use are not recoverable under this warranty.

In the event of a defect in material or workmanship covered by this warranty, Huali Trading, at its sole discretion, will repair the defective product with replacement parts or replace it with the same or a comparable product. We reserve the right to require damaged parts to be returned to us upon request. Natural markings such as scars, brands, grain variations, wrinkles, colour variations, etc. will be considered normal characteristics and not construed as defects.

For claims or questions converting this warranty, please contact Huali Trading Customer Service department via email on services@hualitrading.com.au or the retailer the product was purchased from.

Huali Trading’s sole obligation and the users exclusive remedy under this warranty shall be limited to the repair, credit (only applies to distributors) or replacement at Huali Tradings’ sole discretion and cost, of product or components under the **“COMPETITION AND CONSUMER ACT 2010”**.

“Our goods come with guarantees that cannot be excluded under the Australian Consumer Law. You are entitled to a replacement or refund for a major failure and for compensation for any other reasonably foreseeable loss or damage. You are also entitled to have the goods repaired or replaced if the goods fail to be of acceptable quality and the failure does not amount to a major failure”.

Models: THEA-T-FM2S2

Rating 220-240V AC, 50/60Hz, 2.5A



Models:	THEA-T-FM2S2
Desk Top Dimensions (Metric):	1400 x 700mm
Desk Top Dimensions (Imperial):	55.1 X 27.6"
Height Range:	735 - 1180mm/28.9 - 46.5"
Maximum Load of Desk Top (inclusive of Desk Top):	120kg/264lb
Frame Construction:	Steel
Desk Top Construction:	Compact board
Adapter Input Voltage:	100 - 240V AC 2.5A
Adapter Output Voltage:	29V, 3A
Number of Motors:	2
DC Motor Input Voltage:	24V DC, 3A
Motor Speed (Vertical Lift):	30mm/s
Noise Level:	<48dB
Controller Input Voltage:	29V DC
Controller Output Voltage:	24V DC 4A
Number of Presets:	2
Power Cord Plug Types:	Type-I
Intended Use Temperature Range:	-20°C to 50°C
Intended Use Humidity Range:	RH 40% - 80%